

Butterfly valves
Vannes papillon
Válvulas de mariposa
Válvulas de borboleta

**Lever, Gear &
Actuated Series**

05

- Complete range of sizes
- Several standards available
- 100% factory tested
- Electric & pneumatic actuators available

- Une gamme très complète
- Différents standards disponibles
- 100% des vannes testées en usine
- Motorisations électriques et pneumatiques disponibles

- Completa gama de medidas
- Disponible en diferentes standards
- Probadas al 100% en fábrica
- Motorizaciones eléctricas y neumáticas disponibles

- Gama completa de medidas
- Disponível em diferentes standards
- Testadas em fábrica a 100%
- Disponíveis actuadores eléctricos e pneumáticos

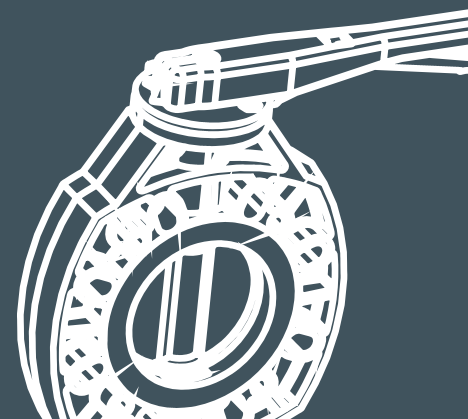

Butterfly Valves

Range

- Sizes from 63 mm to 250 mm (2"-10").

Standards

- Standards: ISO/DIN, ANSI/ASTM, British Standard, JIS.

Working pressure

- At 20°C D63 - D140 (2"-5") PN 10 (150 PSI @ 73°F)
- D160 - D250 (6"-10") PN 6 (90 PSI @ 73°F)

Features

- PVC-U body.
- EPDM or Viton® rubber seal.
- Low maintenance.
- Competitive price.
- Excellent flow characteristics.
- Good mechanical strength.
- Ideally suited for flow control using minimal piping space.

Dimensions

- Dimensions du D63 mm au D250 mm (2"-10").

Standards

- Standards: ISO/DIN, ANSI/ASTM, British Standard, JIS.

Pression de service

- A 20°C D63 - D140 (2"-5") PN 10 (150 PSI @ 73°F)
- D160 - D250 (6"-10") PN 6 (90 PSI @ 73°F)

Caractéristiques

- Corps de vanne en PVC-U.
- Garniture du papillon EPDM ou Viton®.
- Très grande résistance au vieillissement.
- Prix très compétitif.
- Excellentes caractéristiques de conduction.
- Bonne résistance mécanique.
- Encombrement très faible.

Medidas

- Medidas desde 63 mm hasta 250 mm (2"-10").

Standards

- Standards: ISO/DIN, ANSI/ASTM, British Standard, JIS.

Presión de servicio

- A 20°C D63 - D140 (2"-5") PN 10 (150 PSI @ 73°F)
- D160 - D250 (6"-10") PN 6 (90 PSI @ 73°F)

Características

- Cuerpo en PVC-U.
- Junta de la compuerta en EPDM o Viton®.
- Larga vida sin mantenimiento.
- Precio competitivo.
- Excelentes características de conducción.
- Buena resistencia mecánica.
- Ideal para el control del fluido usando poco espacio.

Medidas

- Medidas desde 63 mm até 250 mm (2"-10").

Standards

- Standards: ISO/DIN, ANSI/ASTM, British Standard, JIS.

Pressão de serviço

- A 20°C D63 - D140 (2"-5") PN 10 (150 PSI @ 73°F)
- D160 - D250 (6"-10") PN 6 (90 PSI @ 73°F)

Características

- Corpo em PVC-U.
- Junta da comporta em EPDM ou Viton®.
- Longa duração sem manutenção.
- Preço competitivo.
- Excelentes características de condução.
- Boa resistência mecânica.
- Ideal para o controlo de fluídos usando pouco espaço.

Butterfly valves Vannes papillon Válvulas de mariposa Válvulas de borboleta



Materials / Matériaux / Materiales / Materiais

Parts

- Body
- Valve Disc
- Rubber Seal
- Shaft
- O-Ring Seal
- Top Bearing
- Throttle plate
- Lever-lock
- Handle
- * Screw set in stainless steel

Pièces

- Corps de vanne
- Papillon
- Garniture du papillon
- Axe
- Joints toriques de l'axe
- Douille
- Plateau
- Levier
- Poignée
- * Visserie en acier inoxydable

Despiece

- Cuerpo
- Compuerta
- Junta compuerta
- Eje
- Junta eje
- Casquillo guía
- Conjunto divisor
- Gatillo de la maneta
- Maneta
- * Tornillería en acero inoxidable

Peças

- Corpo
- Comporta
- Junta comporta
- Eixo
- Junta eixo
- Casquilho guia
- Conjunto divisor
- Gatilla de la maneta
- Manipulo
- * Parafusos em aço inoxidável

D63 - D225



- 1 PVC-U
- 2 PVC-U
- 3 EPDM / Viton®
- 4 EPDM / Viton®
- 5 Stainless steel / Zinc plated steel
- 6 Stainless steel / Zinc plated steel
- 7 PE
- 8 PE
- 9 Aluminum

D250



Dimensions / Dimensions / Dimensiones / Dimensões

D63 - D225

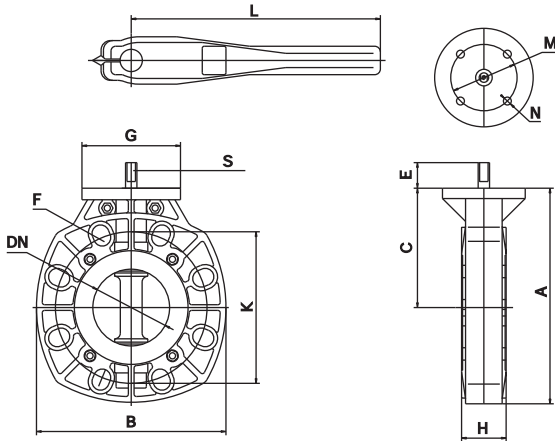

D250

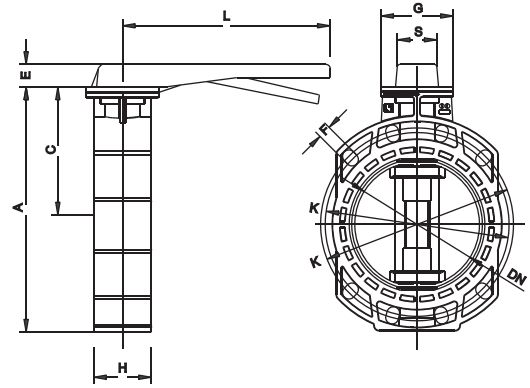

D		A		B		C		E		F		G		H		K		L		M		N		S	
mm	"	mm	"	mm	"	mm	"	mm	"	mm	"	mm	"	mm	"	mm	"	mm	"	mm	"	mm	"	mm	"
63-75	2½"	192	7.56	165	6.50	110	4.33	27	1.06	18 x 4	0.71 x 0.16	104	4.09	48	1.89	125/145	4.92/5.71	228	8.98	70	2.76	9	0.35	10	0.39
90	3"	227	8.94	200	7.87	126	4.96	27	1.06	18 x 8	0.71 x 0.31	104	4.09	53	2.09	160/169	6.30/6.65	263	10.35	70	2.76	9	0.35	12	0.47
110	4"	271	10.67	229	9.02	156	6.14	30	1.18	18 x 8	0.71 x 0.31	104	4.09	60	2.36	180/190	7.09/7.48	263	10.35	70	2.76	9	0.35	16	0.63
125-140	5"	297	11.69	250	9.84	172	6.77	30	1.18	18 x 8	0.71 x 0.31	104	4.09	66	2.60	190/210	7.48/8.27	350	13.78	70	2.76	9	0.35	20	0.79
160	6"	327	12.87	285	11.22	185	7.28	30	1.18	22 x 8	0.87 x 0.31	104	4.09	72	2.83	240	9.45	350	13.78	70	2.76	9	0.35	20	0.79
200-225	8"	400	15.75	340	13.39	230	9.06	30	1.18	22 x 8	0.87 x 0.31	136	5.35	73	2.87	270/295	10.63/11.61	390	15.35	102	4.02	11	0.43	26	1.02
250	10"	450	17.72	319	12.56	250	9.84	37	1.46	24 x 12	0.94 x 0.47	136	5.35	108	4.25	345/362	13.58/14.25	390	15.35	102	4.02	11	0.43	22	0.87

Operating torque at maximum working pressure
Couple de manoeuvre à la pression maximale de service
Par de maniobra a la presión máxima de servicio
Par de manobra à pressão máxima de serviço

Pressure / Temperature Graph
Diagramme Pression / Température
Diagrama Presión / Temperatura
Diagrama Pressão / Temperatura

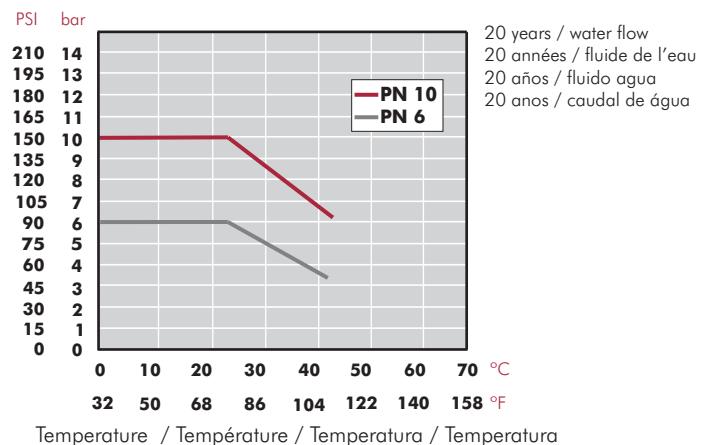
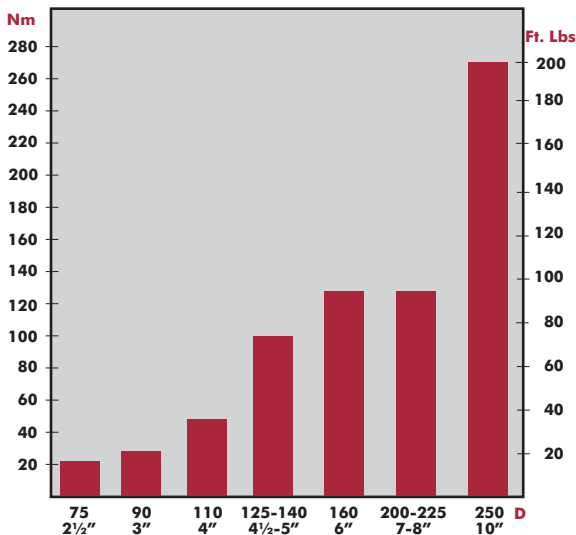

20 years / water flow
 20 années / fluide de l'eau
 20 años / fluido agua
 20 anos / caudal de água

Range

- Sizes from 63 mm to 250 mm (2"-10").

Standards

- Standards: ISO/DIN, ANSI/ASTM, British Standard, JIS.

Working pressure

- At 20°C D63 - D140 (2"-5") PN 10 (150 PSI @ 73°F)
- D160 - D250 (6"-10") PN 6 (90 PSI @ 73°F)

Features

- PVC-U body.
- EPDM or Viton® rubber seal.

Dimensions

- Du D63 mm au D250 mm (2"-10").

Standards

- Standards: ISO/DIN, ANSI/ASTM, British Standard, JIS.

Pression de service

- A 20°C D63 - D140 (2"-5") PN 10 (150 PSI @ 73°F)
- D160 - D250 (6"-10") PN 6 (90 PSI @ 73°F)

Caractéristiques

- Corps de vanne en PVC-U.
- Garniture du papillon en EPDM ou Viton®.

Medidas

- Medidas desde 63 mm hasta 250 mm (2"-10").

Standards

- Standards: ISO/DIN, ANSI/ASTM, British Standard, JIS.

Pressão de serviço

- A 20°C D63 - D140 (2"-5") PN 10 (150 PSI @ 73°F)
- D160 - D250 (6"-10") PN 6 (90 PSI @ 73°F)

Características

- Corpo em PVC-U.
- Junta da comporta em EPDM ou Viton®.

Medidas

- Medidas desde 63 mm até 250 mm (2"-10").

Standards

- Standards: ISO/DIN, ANSI/ASTM, British Standard, JIS.

Pressão de serviço

- A 20°C D63 - D140 (2"-5") PN 10 (150 PSI @ 73°F)
- D160 - D250 (6"-10") PN 6 (90 PSI @ 73°F)

Características

- Corpo em PVC-U.
- Junta da comporta em EPDM ou Viton®.

With Hand Wheel Gear Box Avec Reducteur Manuel Con Reductor Manual Com Redutor Manual



Materials / Matériaux / Materiales / Materiais

Parts

1. Body
2. Valve Disc
3. Rubber Seal
4. Shaft
5. O-Ring Seal
6. Top Bearing
7. Gear Box

Pièces

1. Corps
2. Papillon
3. Garniture du papillon
4. Axe
5. Joints toriques de l'axe
6. Douille
7. Réducteur manuel

Despiece

1. Cuerpo
2. Compuerta
3. Junta compuerta
4. Eje
5. Junta eje
6. Casquillo guía
7. Reductor manual

Peças

1. Corpo
2. Comporta
3. Junta comporta
4. Eixo
5. Junta eixo
6. Casquilho guia
7. Manípulo

D63 - D225



- 1 PVC-U
- 2 EPDM / Viton®
- 3 Stainless steel
- 4 Zinc plated steel
- 5 PE
- 6 Aluminum

D250

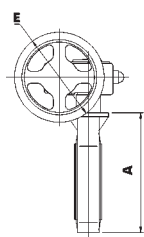
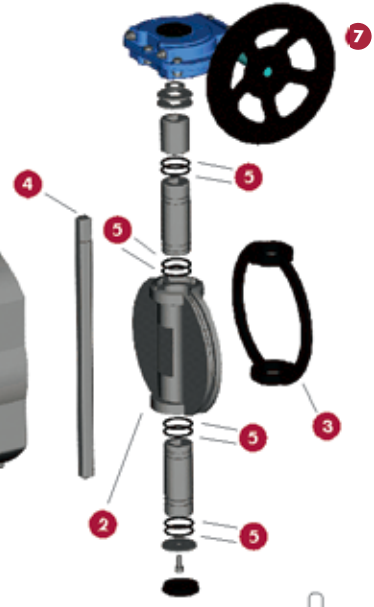

Option 1
Option 1
Opción 1
Opção 1

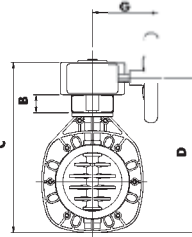

Option 2
Option 2
Opción 2
Opção 2

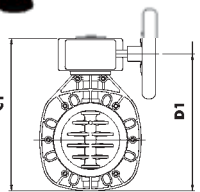

D		A		E		OPTION 1				OPTION 2					
mm	"	mm	"	mm	"	B	C	D		C1	D1				
63-75	2½"	192	7.56	160	6.30	50	1.97	315	12.40	279	10.98	265	10.43	229	9.02
90	3"	227	8.94	160	6.30	50	1.97	350	13.78	313	12.32	300	11.81	263	10.35
110	4"	271	10.67	160	6.30	50	1.97	394	15.51	357	14.06	344	13.54	307	12.09
125-140	5"	297	11.69	160	6.30	50	1.97	420	16.54	383	15.08	370	14.57	333	13.11
160	6"	327	12.87	160	6.30	50	1.97	420	16.54	413	16.26	400	15.75	363	14.29
200-225	8"	400	15.75	310	12.20	50	1.97	523	20.59	486	19.13	473	18.62	436	17.17
250	10"	450	17.72	310	12.20	-	-	-	-	-	-	490	19.29	520	20.47

Butterfly Valves

Range

- Sizes from 63 mm to 250 mm (2"-10").

Working pressure

- At 20°C D63 - D140 (2"-5") PN 10 (150 PSI @ 73°F)
- D160 - D250 (6"-10") PN 6 (90 PSI @ 73°F)

Features

Electric actuator:

- Electric actuators J+J and Valpes.
- Available voltages:
J+J: 12-48 V AC-DC / 80-240 V AC-DC
VALPES: 12-24 V AC-DC / 115 & 230 V AC
- Manual override and visual position indicator.
- Torque limiter.
- BSR Safety Block.
- DPS (Digital Positioner System). 4-20 mA ó 0-10 V.

Pneumatic actuator:

- Pneumatic actuators CH-Air and Prisma.
- Double-acting or spring return.
- On order: electric valve, relief regulators and limit-switch box.

Dimensions

- Du D63 mm au D250 mm (2"-10").

Pression de service

- A 20°C D63 - D140 (2"-5") PN 10 (150 PSI @ 73°F)
- D160 - D250 (6"-10") PN 6 (90 PSI @ 73°F)

Caractéristiques

Actionneur électrique:

- Actionneurs électriques J+J et Valpes.
- Voltages disponibles:
J+J: 12-48 V AC-DC / 80-240 V AC-DC
VALPES: 12-24 V AC-DC / 115 et 230 V AC
- Commande manuelle d'urgence avec indicateur visuel de position.
- Limiteur de couple.
- Bloquage de sécurité.
- DPS (Système de positionneur digital). 4-20 mA ó 0-10 V.

Actionneur pneumatique:

- Actionneurs pneumatiques CH-Air et Prisma.
- Double ou simple effet.
- Sur commande: électrovanne, boîtiers fin de course et régulateur d'échappement.

Medidas

- Medidas desde 63 mm hasta 250 mm (2"-10").

Presión de servicio

- At 20°C D63 - D140 (2"-5") PN 10 (150 PSI @ 73°F)
- D160 - D250 (6"-10") PN 6 (90 PSI @ 73°F)

Características

Actuador eléctrico:

- Actuadores eléctricos J+J y Valpes.
- Voltajes disponibles:
J+J: 12-48 V AC-DC / 80-240 V AC-DC
VALPES: 12-24 V AC-DC / 115 y 230 V AC
- Mando manual de emergencia e indicador visual de posición.
- Limitador de par.
- Bloque de seguridad.
- DPS (sistema posicionador digital). 4-20 mA ó 0-10 V.

Actuador neumático:

- Actuadores neumáticos CH-Air y Prisma.
- Doble efecto y simple efecto.
- Bajo pedido: electroválvula, finales de carrera y reguladores de escape.

Medidas

- Medidas desde 63 mm até 250 mm (2"-10").

Pressão de serviço

- At 20°C D63 - D140 (2"-5") PN 10 (150 PSI @ 73°F)
- D160 - D250 (6"-10") PN 6 (90 PSI @ 73°F)

Características

Actuador eléctrico:

- Actuadores eléctricos J+J e Valpes.
- Voltagem disponíveis:
J+J: 12-48 V AC-DC / 80-240 V AC-DC
VALPES: 12-24 V AC-DC / 115 e 230 V AC
- Controlo manual de emergência e indicador manual de posição.
- Limitador de par.
- Bloqueio de segurança.
- DPS (sistema posicionador digital). 4-20 mA ó 0-10 V.

Actuador pneumático:

- Actuadores pneumáticos CH-Air e Prisma.
- Efeito duplo ou efeito simples.
- Sob pedido: electroválvula, fins de curso e reguladores de saída.

Actuated Valves Robinets Motorisés Válvulas Motorizadas Válvulas Motorizadas

Electric Actuator Actionneur Electrique Actuador Eléctrico Actuador Eléctrico

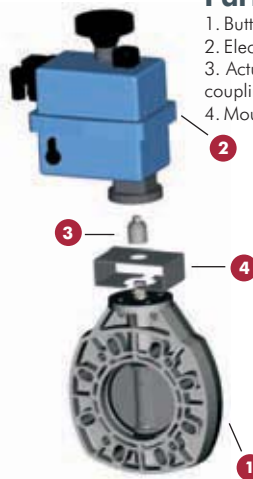

Parts

- Butterfly valve
- Electric actuator
- Actuator-valve coupling bush
- Mounting clamp

Pièces

- Vanne papillon
- Actionneur électrique
- Douille de raccordement actionneur-vanne
- Bride de fixation

Despiece

- Válvula de mariposa
- Actuador eléctrico
- Casquillo unión actuador-válvula
- Brida de unión

Peças

- Válvula de borboleta
- Actuador eléctrico
- Casquilho união actuador-válvula
- Manilha de união

Diameter		Dimension "E"	
Diamètre	Cote "E"	Cote "E"	Cote "E"
Diámetro	Cota "E"	Cota "E"	Cota "E"
Diámetro	Cota "E"	Cota "E"	Cota "E"
mm	"	mm	"
63-75	2½"	160	6,30
90	3"	176	6,93
110	4"	207	8,15
125-140	5"	222	8,74
160	6"	234	9,21
200-225	8"	295	11,61
250	10"	250	9,84

Dimension "E" to valve centre
Cote "E" par rapport au centre de la vanne
Cota "E" a centro de la válvula
Cota "E" ao centro da válvulas

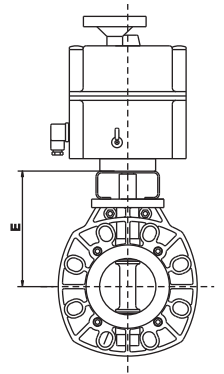

Pneumatic Actuator Actionneur Pneumatique Actuador Neumático Actuador Pneumático



Parts

- Butterfly valve
- Mounting clamp
- Coupling bush
- Pneumatic actuator
- Limit-switch box
- Electric valve

Pièces

- Vanne papillon
- Bride de fixation
- Douille d'accouplement
- Actionneur pneumatique
- Boîtier fin de course
- Electric valve

Despiece

- Válvula de mariposa
- Brida fijación
- Casquillo unión
- Actuador neumático
- Caja finales de carrera
- Electroválvula

Peças

- Válvula de borboleta
- Manilha fixação
- Casquilho união
- Actuador pneumático
- Caixa fim de curso
- Electroválvula

Diameter		Dimension "E"	
Diamètre	Cote "E"	Cote "E"	Cote "E"
Diámetro	Cota "E"	Cota "E"	Cota "E"
Diámetro	Cota "E"	Cota "E"	Cota "E"
mm	"	mm	"
63-75	2½"	78	3,07
90	3"	78	3,07
110	4"	78	3,07
125-140	5"	92	3,62
160	6"	92	3,62
200-225	8"	92	3,62
250	10"	101	3,98

Dimension "E" to valve centre
Cote "E" par rapport au centre de la vanne
Cota "E" a centro de la válvula
Cota "E" ao centro da válvulas

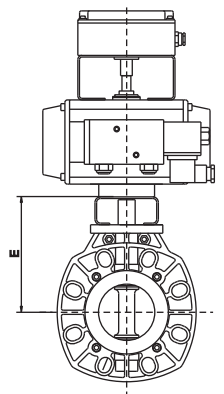

Pressure loss chart
Diagramme de pertes de charge
Diagrama de pérdidas de carga
Diagrama de perdas de carga

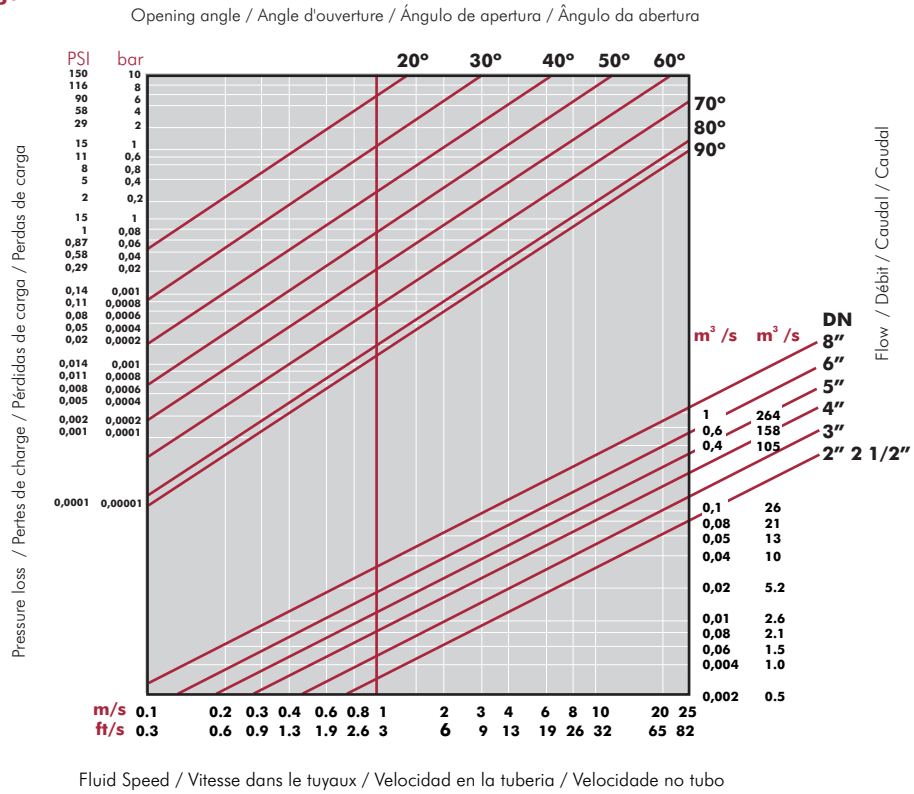

Versions
Versions
Versiones
Verções



Without Flanges
 Sans Brides
 Sin bridas
 Sem Flanges



Flange adaptor + backing ring
 Collet porte brides + brides mobiles
 Brida + manguito
 União colarinho + flange móvel



Fixed flange
 Collet bride
 Brida fija
 Flange fixa

Different type of joints (see dot color)
Différents types de joints (voir couleur de la pastille)
Varios tipos de juntas (ver color de la pastilla)
Vários tipos de juntas (veja a cor do distintivo)

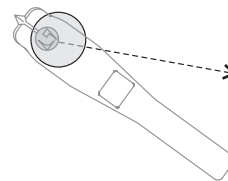

Av. Ramon Cuirans, 40 - Pol. Ind. Congost - Parcel·la 6
 08530 La Garriga (Barcelona) Spain
 Tel.: +34 93 870 42 08 - Fax: +34 93 870 98 11
 E-mail: cepex@cepex.com
 Website: www.cepex.com

FOR MORE INFORMATION VISIT
www.cepex.com